



BENEDICTION ENTERPRISE CO., LTD.



BDE-2007

Weighing Indicator & Controller

User's Manual

Contents

* CHAPTER 1 INTRODUCTION

1-1 Items in Carton ----- 1

* CHAPTER 2 INSTALLATION

2-1 Best Conditions for Use ----- 2

2-2 Connecting the Load Cell ----- 2

2-3 Front and Rear Panel Dimensions ----- 3

* CHAPTER 3 SPECIFICATIONS

3-1 Analog Input and A/D Conversion ----- 5

3-2 General ----- 5

3-3 Front Panel Description ----- 6

* CHAPTER 4 SYSTEM FUNCTIONS

4-1 System Check ----- 8

4-2 Functions ----- 8

4-3 Calibration - ----- 15

4-4 System Initialize ----- 16

4-5 Accumulation ----- 17

* CHAPTER 5 SET POINTS

5-1 Set Points ----- 17

5-2 Batching Modes ----- 18

* CHAPTER 6 OPTIONS

6-1 I/O Interface ----- 25

6-2 Serial Interface ----- 27

6-3 Analog Output ----- 31

6-4 Relay control interface OP-08 ----- 33

6-5 Modbus ----- 34

CHAPTER 1 INTRODUCTION

§ 1-1 Welcome

The BDE-2007-6KEY weighing indicator can be applied to many industries. The purpose of designing BDE-2007-6KEY is to perform quick and accurate controls. Please contact us immediately for further technical services and support if needed.

E-mail: bde.com@msa.hinet.net Website : www.bde.com.tw

§ 1-2 Features

- ◎ 1/30,000 high displayed resolution. A/D conversion rate: 120 times/sec.
- ◎ Watchdog virtually eliminates malfunctions that associated with computerized equipment or software failure.
- ◎ Full Digital Calibration makes setting ZERO and SPAN Calibration an easy task.
- ◎ Drives up to 8 parallel connecting load cells.
- ◎ The settings of function and weighing parameters are all stored in the EEPROM, with storage duration over 40 years.
- ◎ Important values and parameters can have storage backup.
- ◎ Users can adjust the intensity of digits filter to avoid mechanical vibration that caused by external environments to achieve high speed and accurate measurement.
- ◎ 8 sets of Control Input and Output can be applied to many control applications.
- ◎ Build-in RS-232 Interface.
- ◎ Options:
 - OP-01 Control I/O (8/8)
 - OP-02A Serial Interface RS-232
 - OP-02B RS-485 / Modbus (RTU)
 - OP-05 Analog Output (4-20 mA)
 - OP-06 Analog Output (0-10 V)
 - OP-08 Relay Control Interface (added on OP-01)
 - OP-09-01 Power Supply
 - OP-09-02 12 VDC Adaptor

§ 1-3 Items in Carton

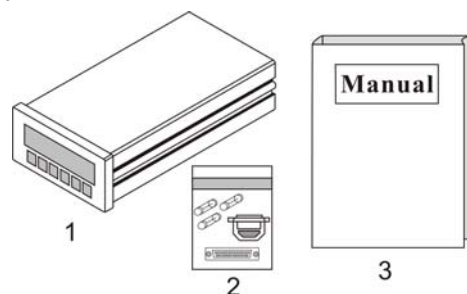

IndicatorX1, Accessory pack (in plastic bag) X 1, and User manual in the carton.

CHAPTER 2 INSTALLATION

§ 2-1 Best Conditions for Use

When installing and wire connecting on BDE-2007-6KEY, please follow the points and guide for preventing any abnormal situation occurred.

- ◎ Before connecting the Electric Power Supply, please identify the input electric voltage type is DC 12V or DC 24V. WE MUST CONFIRM POSITIVE AND NEGATIVE DC INPUT!!
- ◎ The operation temperature shall range within 0°C~45°C, please DO NOT install in any place of direct sunlight.
- ◎ Due to the minute output signal from load cell, please use isolated cables and separate the load cell cable from the power supply cable and control I/O cables.
- ◎ The input power shall be DC 12V or DC 24V ±10%, if the electric power supply is not stable or the interference signal exists, that may cause uncertain actuation or reaction, even damage. Therefore, please utilize electric power supply stabilizer of adequate capacity.

§ 2-2 Connecting the Load Cell

DO NOT turn on power until you make sure the right load cell connection.

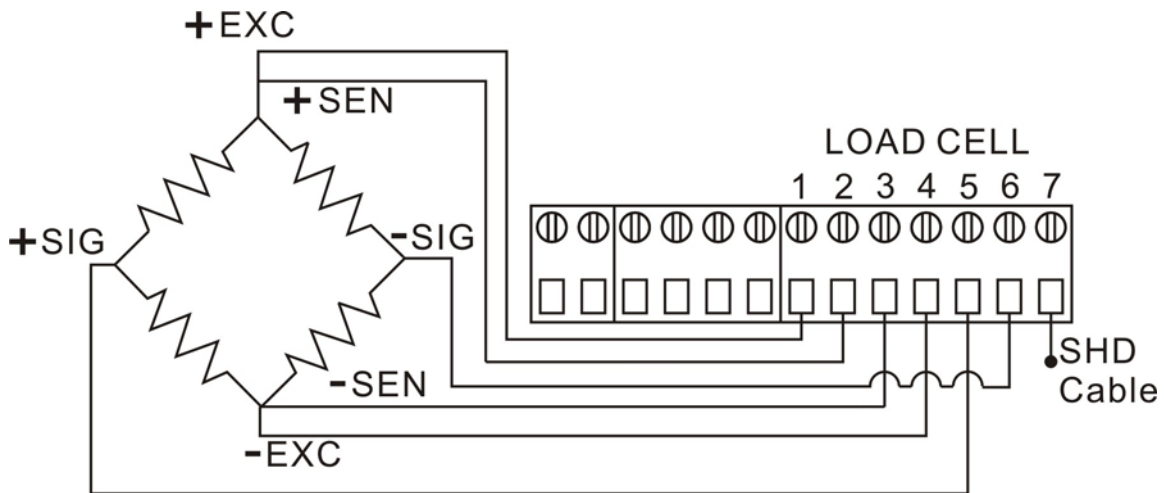

Screw	Signal
1	Positive Excitation Voltage (EXC+)
2	Positive Sense Voltage (SEN+)
3	Negative Sense Voltage (SEN-)
4	Negative Excitation Voltage (EXC-)
5	Positive Signal Voltage (SIG+)
6	Negative Signal Voltage (SIG-)
7	Shield (SHD)

① If you use a six-wire cable with shield to connect your load cell to the weighing indicator, please connect the wires as indicated above.

① The analog output from the Load Cell and Input/Output signals are sensitive to electrical noise. Do not bind these cables together as it could result in cross-talk interface. Please keep them away from AC power cables.

§ 2-3 Front and Rear Panel Dimensions

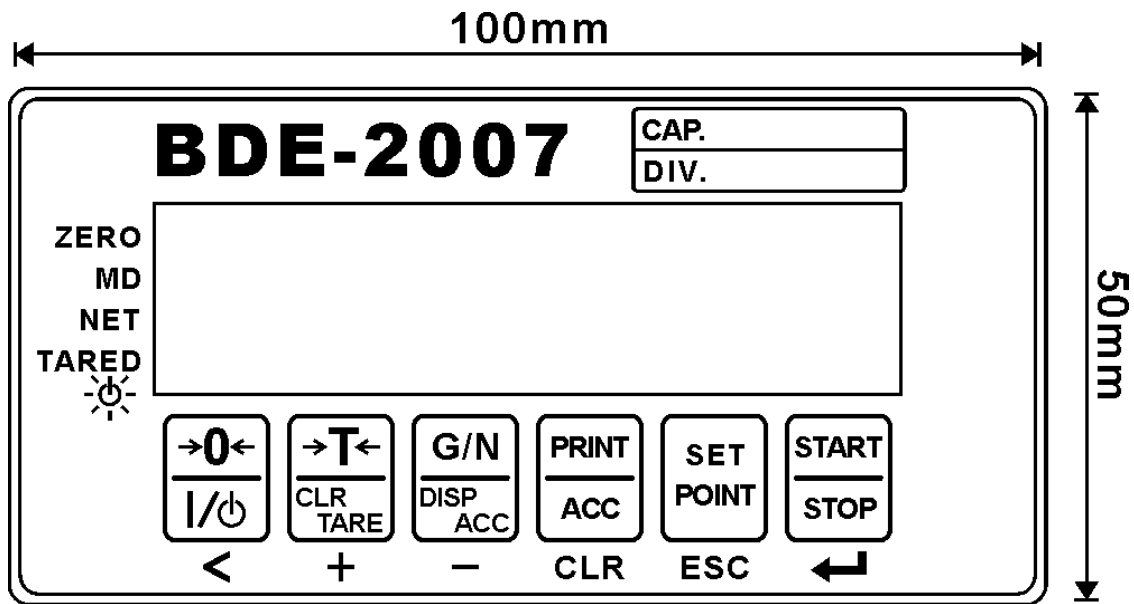

Front View of BDE-2007-6KEY

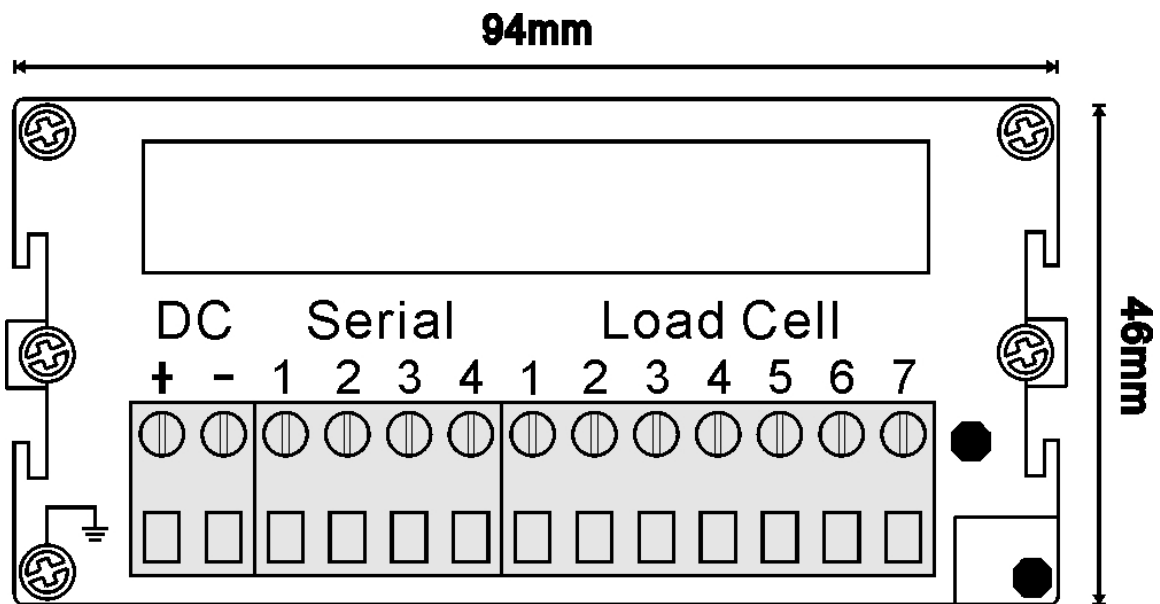

Rear View of BDE-2007-6KEY

§ 2-4 Side View and Mounting Dimensions



Side View of BDE-2007-6KEY

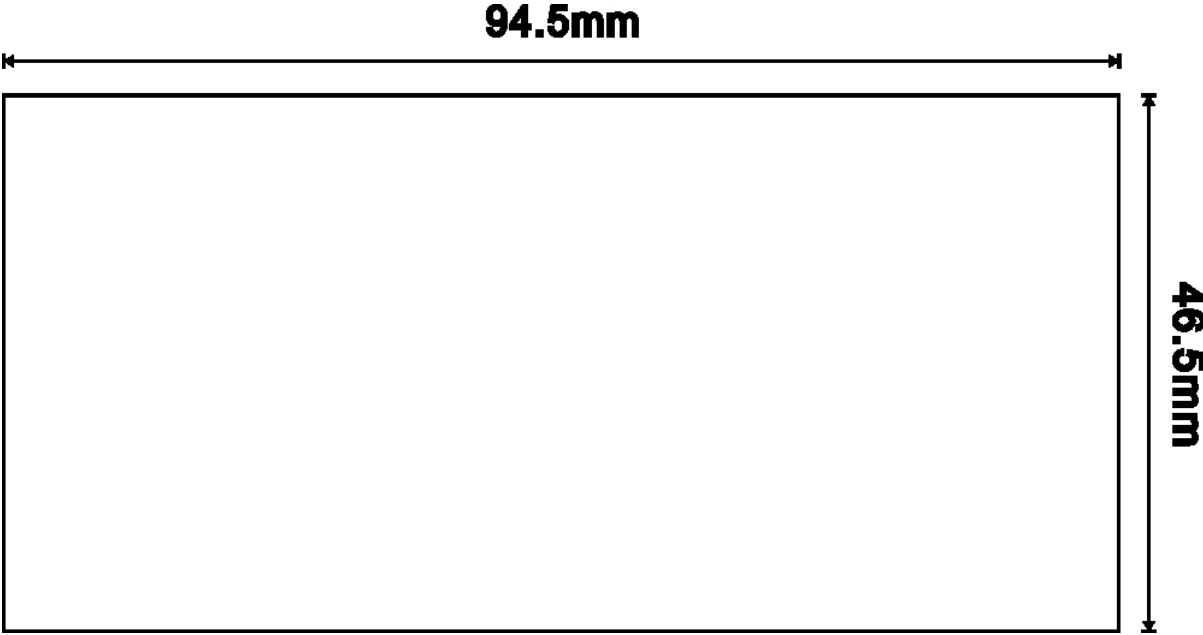

Mounting Cut for BDE-2007-6KEY

CHAPTER 3 SPECIFICATIONS

§ 3-1 Analog Input and A/D Conversion

◎ Analog Input and A/D Conversion	
Model	BDE-2007-6KEY
Input Sensitivity	0.12 μ V/D or above
ZERO Adjustment Range	0 ~ 12mV
Load Cell Excitation	DC 5V \pm 5%, 120mA, Remote sensing. It can be connected up to 8 load cells (350 Ω).
Non-Linearity	\pm 0.01% F.S
A/D Conversion Method	$\Delta \Sigma$
A/D Resolution	\approx 1/1,000,000
A/D Conversion Rate	120 times / sec.
Max. Load Cell Input Voltage	20mV
ZERO Temperature Comp.	\pm (0.2 μ V + 0.001% of dead load) / $^{\circ}$ C typ
SPAN Temperature Comp.	\pm 0.001% / $^{\circ}$ C typ
Max. Resolution	1/30,000

§ 3-2 General

◎ General	
Model	BDE-2007-6KEY
Power Requirement	DC 12V or DC 24V \pm 10%, 400mA
Net Weight	\approx 490g
Maximum Humidity	85%
Operation Temperature	-10~45 $^{\circ}$ C
Dimensions	155 (D) \times 100 (W) \times 50 (H) mm

§ 3-3 Display and Signs

◎ 3-3-1 Front Panel of BDE-2007-6KEY

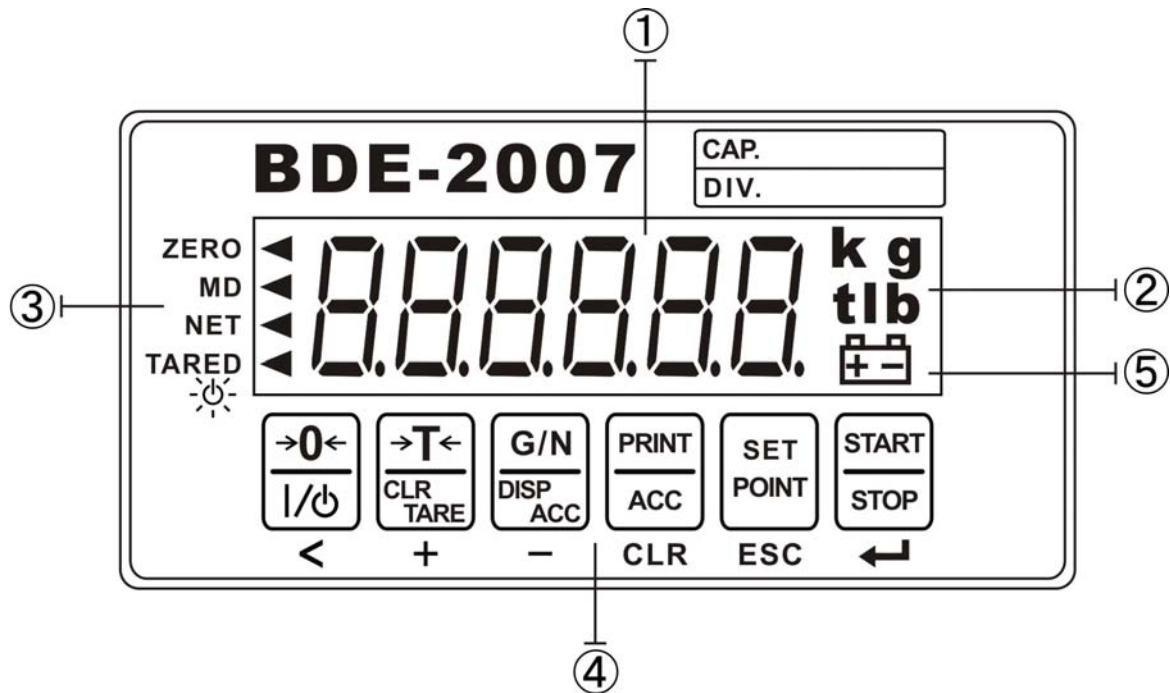

◎ Front Panel Description		
NO.	Display	Description
①	8.8.8.8.8.8	Six digits, including decimal point (positive)
②	Kg、g、t、lb	Unit of measurement
③	" ZERO " ◀ " M.D." ◀ " NET " ◀ " TARED " ◀ " ⏻ " ◀	ZERO Unstable NET TARED Standby Function (blinking)
④		Function key (see <u>*3-3-2</u>)
⑤		DC voltage low

© 3-3-2

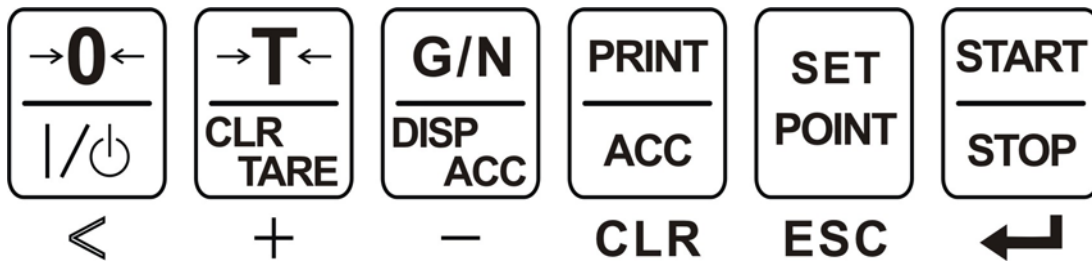

© Keys Description					
Press one time		Press / Hold more than 2 seconds		Edit Operation	
→0← /⏻	Zero/Cancel standby mode	/⏻	Standby	<	Move left when setting
→T←	Tare	CLR TARE	Clear tared weight	+	Increase
G/N	Gross / Net Weight Mode	DISP ACC	Display Count, Accumulation value	-	Decrease
PRINT ACC	Print / Accumulate			CLR	Clear value when setting
SET POINT	Set Point			ESC	Escape / return when setting
START STOP	Start / Stop			↵	Enter value when setting

© 3-3-3 Rear Panel of BDE-2007-6KEY

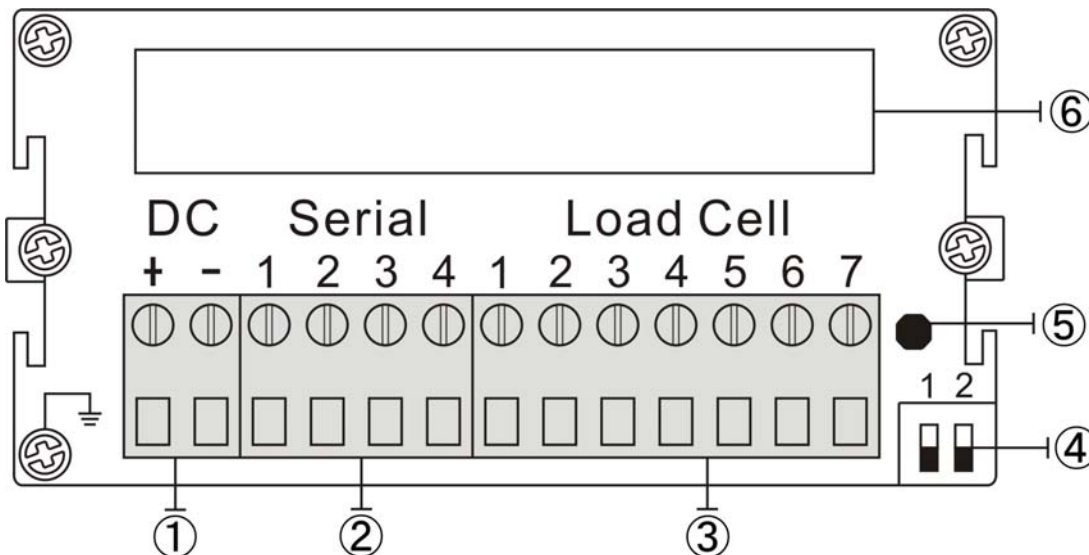

NO.	Description	NO.	Description
①	DC power input	②	Serial interface
③	Load cell input 7 pins	④	SET cover
⑤	Lead sealing screw	⑥	Options hole

CHAPTER 4 SYSTEM FUNCTIONS

§ 4-1 System Check

A system check should be run in the following situations: after initial installation, after moving your BDE-2007-6KEY, after connecting or disconnecting an attachment from the Rear Panel and as means of locating any unexplained system error.

STEP 1: In the weight screen, please hold **G/N** and **SET POINT** key together about 2 seconds, it will display **F-CSET** → **FUNC**.

STEP 2: Press **+** key, it will display **CHECK**, then press **↵** key to start system check.

STEP 3: It will start self-testing to check 7-segment **LED** light by LED blinks of each segment. Please press **↵** key for the next step.

STEP 4: Then it will test EEPROM, showing EE-1. Please check rear panel **SET 1**



is **ON**. Then press **↵** key, it will show **.....** meaning testing now, showing **PASS** means test is OK, showing **Error** means test is fail. If everything is OK, please press **↵** key.

STEP 5: Go on testing **OP-01 I/O**, showing **I-O**, please press **↵** key.

- (1) **OUTPUT:** Use 12V Bulb to test com point with **P13~P6 (Give com PORT WITH 12V POWER)**, if more than 1 pin is **ON** or **OFF** is abnormal. Please press **↵** key for next step.
- (2) **INPUT:** Displays “In”. Please use wire to shortage Pins through Control I/O 25 Pin D SUB, Use Com(P17/16) and (P25~18) with wire shortage. Please use **↵** key for next step.

STEP 6: Check if all keys are OK (You can check them by yourself), it will show

6 5 4 3 2 1

Match → **0** ←, → **T** ←, **G/N**, **PRINT**, **SET POINT**, **START/STOP** with numbers **6 5 4 3 2 1**.

6	5	4	3	2	1
→ 0 ←	→ T ←	G/N	PRINT	SET POINT	START STOP

STEP 7: Switch **SET 1**  **OFF** to **OFF**, Hold **G/N** + **SETPOINT** keys to finish checking.

** **SW-Err** means **SET 1** still not **OFF**  **OFF**.

§ 4-2 Functions

Step 1: In the normal mode, press **G/N** and **SETPOINT** key about 2 seconds, it will display **F-CSET** → **FUNC** then enter functions setting, press **↵** key, displaying **F000**.

Step 2: Use **+-** key to choose **F000 F100** ... **FL00** and press **↵** key getting into main function selection.

Step 3: Press **↵** key, displaying **FX00**, use **+-** key to choose secondary function selection **FX00** ~ **FXXX**.

Step 4: Then press **↵** key again to show what you have set, use **+-** key to enter value.

After entering the value, please press **↵** key to confirm. If you press **ESC** key, then it will not save the value that you already set or changed, and will skip to next step.

Step 5: Press **ESC** key, and back to last layer. Please hold **ESC** key to end function setting, then it will go back to normal mode.

◎ 4-2-1 General Functions

F000	Decimal Point Adjustment		
	0	No Decimal	123456
	1	1 Decimal	12345.6
	2	2 Decimal	1234.56
●	3	3 Decimal	123.456

F001	Weighing Unit Selection	
	0	None
	1	g
●	2	kg
	3	ton
	4	lb

F002	Display Update Rate	
	5	5 times / second
	10	10 times / second
●	20	20 times / second
	40	40 times / second

F003	Digital Filter				
			Filter	Environment Vibration	Response Speed
	0	No Stage	Weak	Bad	Fast
	1	1 st Stage			
	2	2 nd Stage			
	3	3 rd Stage	▲	▲	▲
●	4	4 th Stage	▼	▼	▼
	5	5 th Stage			
	6	6 th Stage			
	7	7 th Stage	Strong	Good	Slow

F004	Set ZERO Range	
	5	± 5% of Weighing Platform Full Capacity
●	10	±10% of Weighing Platform Full Capacity
	20	±20% of Weighing Platform Full Capacity
	30	±30% of Weighing Platform Full Capacity

F005	Motion Detection				
	00	Stable			
	01	0.5 SEC., 1 DIV.		11	1 SEC., 1 DIV.
	02	0.5 SEC., 2 DIV.	●	12	1 SEC., 2 DIV.
	03	0.5 SEC., 3 DIV.		13	1 SEC., 3 DIV.
	04	0.5 SEC., 4 DIV.		14	1 SEC., 4 DIV.
	05	0.5 SEC., 5 DIV.		15	1 SEC., 5 DIV.
	06	0.5 SEC., 6 DIV.		16	1 SEC., 6 DIV.
	07	0.5 SEC., 7 DIV.		17	1 SEC., 7 DIV.
	08	0.5 SEC., 8 DIV.		18	1 SEC., 8 DIV.

F006	Automatic ZERO Tracking Compensation				
	00	OFF			
	11	1 SEC., 0.5 DIV.		21	2 SEC., 0.5 DIV.
	12	1 SEC., 1 DIV.		22	2 SEC., 1 DIV.
	13	1 SEC., 1.5 DIV.		23	2 SEC., 1.5 DIV.
●	14	1 SEC., 2 DIV.		24	2 SEC., 2 DIV.
	15	1 SEC., 2.5 DIV.		25	2 SEC., 2.5 DIV.
	16	1 SEC., 3 DIV.		26	2 SEC., 3 DIV.
	17	1 SEC., 3.5 DIV.		27	2 SEC., 3.5 DIV.
	18	1 SEC., 4 DIV.		28	2 SEC., 4 DIV.

F007	TARE & ZERO keys Availability	
●	0	TARE & ZERO keys always work
	1	TARE & ZERO keys work only when the display is STABLE.

F008	TARE key Availability (when Gross Weight is minus)	
●	0	TARE keys always work
	1	TARE keys works only when the display is STABLE.

F009	Accumulation Method	
	0	Off
	1	Stable
●	2	Manual
	3	Control Input--Command Accumulation (For Modbus)
	4	Control Input -Command Accumulation

© 4-2-2 Control Functions

F100	Set ZERO Band
6 digits ZERO band value (● Initial “000.000”)	

F101	Batching Mode	
	1	Customer Programmed Control Mode: Normal Batching
	2	Customer Programmed Control Mode: Loss-in-Weight Batching
●	3	Built-in Automatic Program Mode: Normal Batching
	4	Built-in Automatic Program Mode: Loss-in Weight Batching
	5	PEAK Hold Function (Only available when weight value is positive.)

F102	Timer-Comparator Inhibitor
Set between 0.0 and 2.0 sec.	
● Initial: 0.0 sec.	
※ Only apply to Batching Mode (F101) 3 and 4.	

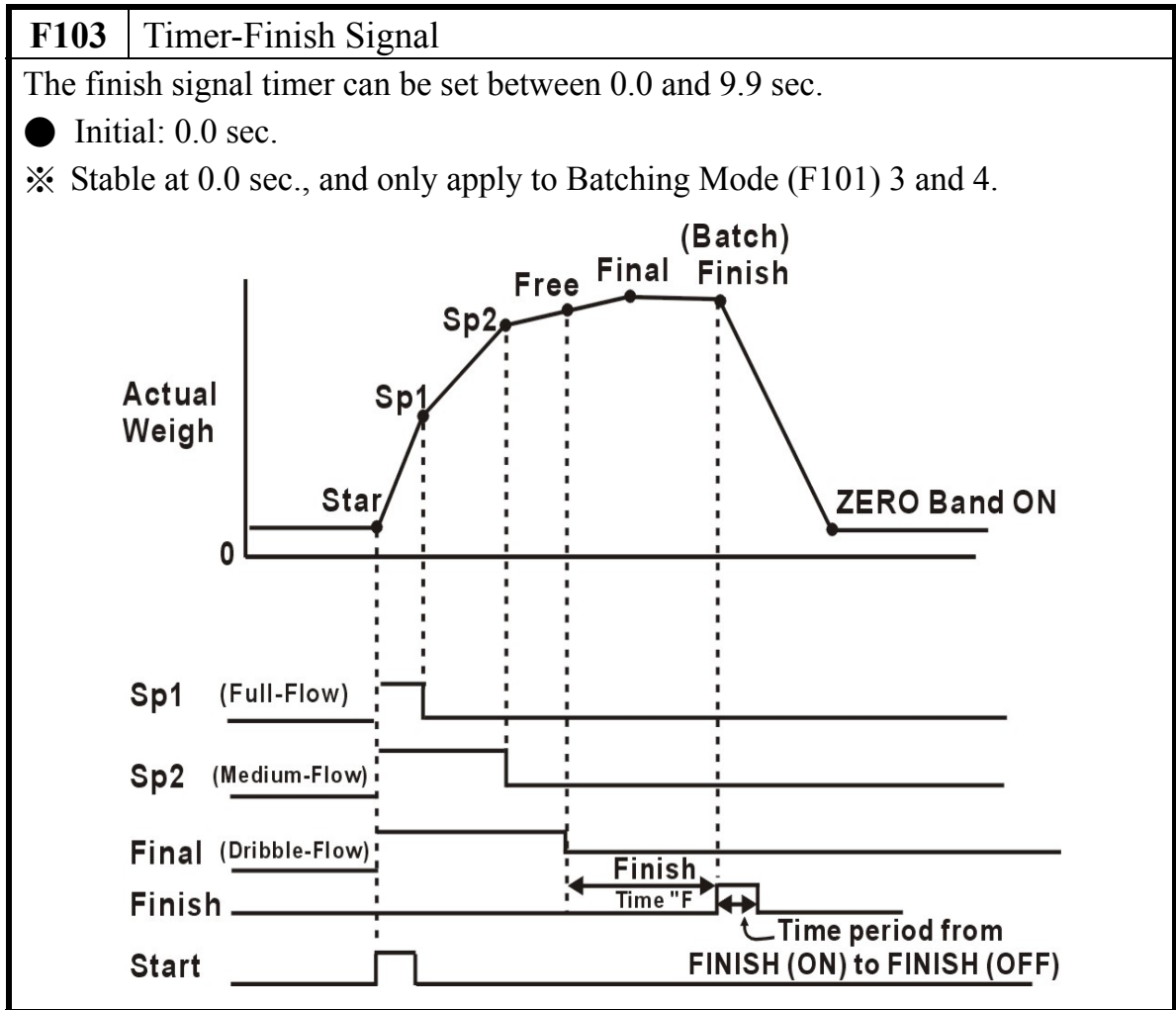

F104	Pulse Width of Finish Signal	
Set between 0.0 and 2.0 sec.		
● Initial: 0.5 sec.		
※ Finish signal sent ON at 0.0 sec., and stays ON until the next START signal.		
※ Only apply to Batching Mode 3 and 4 .		

F105	Output 8	
●	0	Unstable
	1	Error

F106	Input by Batch Start / Stop (Batching Mode 3.4.5)	
	1	Panel Key
●	2	OP-01 Input
	3	OP-02 Serial Input / Modbus
Mode 5 is only apply to option 1, 3.		

F107	Automatic Free Fall Compensation	
Please enter 3 digits Free Fall Compensation Value within effective range		
● Initial: "000.000" Free Fall OFF		

F108	Memory Automatic Free Fall Compensation	
●	0	Memory
	1	Not Memory

© 4-2-3 Serial Input / Output [RS-232]

F200	Baud Rate	
	24	2400BPS
●	48	4800BPS
	96	9600BPS

F201	Set Data Length, Parity, Stop Bit	
	0	D8, N, 1
●	1	D7, E, 1
	2	D7, O, 1
	3	D8, N, 2
	4	D8, E, 1
	5	D8, O, 1
Only 3. 4. 5 applicable to Modbus (RTU)		

F202	Output Data	
●	1	Same as the display
	2	GROSS Weight
	3	NET Weight
	4	TARE Weight
	5	GROSS Weight, NET Weight, TARE Weight

F203	Output Mode	
●	1	Stream
	2	Stable and Automatic Print
	3	Manual Print Mode
	4	Accumulate and Print
	5	For RS-232 Commanding
	6	For Modbus Commanding

F204	Serial Address (RS-485)
00- Not used (● Factory set at 00)	
00-99-Used	

F205	RS-232 Models Selection (Only applicable to F202=1. 2. 3 ; F203=1. 2. 3. 4)	
●	0	Standard
	1	BDI-9301
	2	IQ-350
	3	HB-8210

◎ 4-2-4 Analog Output

F500	Analog Output Data	
●	1	Output 4~20mA
	2	Output 0~+10V

F501	Output Mode	
●	1	Same as the Display
	2	GROSS Weight
	3	NET Weight

F502	Loss-in-Weight Absolute Value	
●	0	Not Read Absolute Value
	1	Read Absolute Value

F503	Output Current When Display ZERO	
0.0 through 99.9		
●	Initial 4.0	

F504	Output Current at Full Capacity	
0.0 through 99.9		
●	Initial 20.0	

◎ 4-2-5 BCD Switch

F700	BCD Switch	
●	0	Not Used
	1	Used 【Final Weight, SP1(Set Point 1), FF(Free Fall)】

◎ 4-2-6 Serial Output (RS-232 TxD 2)

FL00	Baud Rate	
●	12	1200BPS
	24	2400BPS

FL01	Output Data	
●	1	Same as the Display
	2	GROSS Weight
	3	NET Weight
	4	TARE Weight
	5	GROSS Weight, NET Weight, Tare Weight

FL02	Output Mode	
●	1	Stream
	2	Stable and automatic print
	3	Manual Print Mode
	4	Accumulate and Print

§ 4-3 Calibration

© 4-3-1 Set Calibration

STEP 1: Turn off the POWER, Rear panel SET 1  ON.

It shows **CAL** → **F-CAL**.

© 4-3-2 Calibration: Choose F-CAL, then Press key.

STEP 1: Display shows **di 01**, use **+ -** key to set Minimum Division, then press  key to enter next step.

STEP 2: Display shows **dp** → **010.000** to set decimal point, use **+ -** key to set decimal point, then press  key to enter next step.

STEP 3: Display shows **CAP** → **010.000**, press **≤** key, use **+ -** key to enter Maximum Capacity, then press  key to enter next step.

STEP 4: Display shows **Zero** to adjust ZERO, please remove the calibration mass and objects from the weighing device, press  key, showing **[.....]**, then will enter next step if no error happens.

STEP 5: Display shows **Span** → **10.000**, please place your calibration mass on the weighing devices and input weight value. Then press  key, showing **[.....]**, then it begins to set Span Calibration.

STEP 6: When finishing the Span Calibration, it will show

End → **2007** → **F-CAL**, please slide the SET 1  OFF to OFF.

Finish calibration, it will return to display of weight value.

◎ Calibration Errors

C.Err 1: The resolution exceeds 1: 30,000.

⇒ Change the minimum division and maximum capacity within 1/30,000.

【Resolution ratio = Minimum division / Maximum capacity】

C.Err 2: The load cell output is too large at ZERO calibration.

⇒ Add an additional resistor (50KΩ~500KΩ) between EXC+ and SIG-. ※Refer to the right figure.

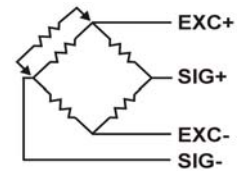

C.Err 3: The load cell output is too small at ZERO calibration.

⇒ Add an additional resistor (50KΩ~500KΩ) between EXC+ and SIG+. ※Refer to the right figure.

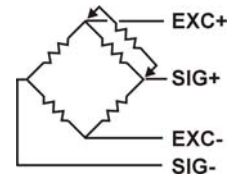

C.Err 4: The calibration mass has been wrongly entered a value which is greater than the maximum capacity.

⇒ Please reduce the weight of calibration mass, and re-enter the weight value.

C.Err 5: The calibration mass has been wrongly entered ZERO or it is smaller than the minimum capacity.

⇒ Please increase the weight of calibration mass, and re-enter the weight value.

C.Err 6: The load cell output is too low.

⇒ Replace your load cell with a more sensitive one or adjust the minimum division.

C.Err 7: The load cell signal pins are reversed or the load cell output voltage is too low.

⇒ Check the load cell connections if reversed or load cell damaged.

C.Err 8: The load cell output voltage at maximum capacity is too high.

⇒ Check the load cell specification or if load cell damaged.

C.Err 9: The maximum capacity has been wrongly entered a value which is smaller than 100.

⇒ Please re-enter the value.

C.Err 10: The maximum capacity has been wrongly entered a value which is greater than 150,000.

⇒ Please re-enter the value.

C.Err 11: Please Clear and Tare first.

⇒ Please make ZERO calibration first.

C.Err 12: Input value is too big or small.

⇒ Please re-enter the value.

§ 4-4 System Initialize

STEP 1: Please slide rear panel SET 1  ON, display shows **CAL** → **F-CAL**.

STEP 2: Press **+** key until it shows **INIT**, then press **↵** key, it will enter Initialization.

STEP 3: Press **+** key to choose **NO** or **YES**. If you choose **NO**, it will show **END**.

finishing operation. If you choose **YES**, it will show **.....** to execute Initialization. When finishing Initialization, it will show **END**.

STEP 4: Please slide rear panel SET 1  OFF, and back to normal mode.

§ 4-5 Accumulation

◎ 4-5-1 Display Accumulation

Press **DISPACC** key more than 2 seconds, it will display Accumulation Count.
Then press **DISPACC** key again, it will show Accumulation Value.
Press **ESC** key to escape display accumulation.

◎ 4-5-2 Clear Accumulation

Operate same as above operation procedure.
Then press **CLR** key, it will display **CLRA.C**, if you are sure to clear Accumulation Value, please press **↵** key to clear Accumulation Value and Accumulation Count.
If you do not want to clear the value, please press **ESC** key to escape.

§ 4-6 Standby Functions

◎ 4-6-1 Standby Function

Please hold the **|/⏻** key when the screen is in normal weight display, the scale will enter standby status.

◎ 4-6-2 Escape Standby Function

Under standby status, please hold **|/⏻** key to escape standby status.

CHAPTER 5 SET POINTS

§ 5-1 Change Set Point Code and Set Point Value

1. Press **SET POINT** key, it will display **SET SP**.
2. Under Mode F101=1/2/3/4 (Batching Mode)

Final	-	Final Value	Six digits
SP1	-	SP1 Value	Six digits
SP2	-	SP2 Value	Six digits
FF	-	Free Fall Value	Four digits
Hi	-	Hi Value	Four digits
Lo	-	Lo Value	Four digits
3. All of above setups, please use **≤** key to choose digit, press **+ -** key to increase or decrease 1 division. Then press **↵** key to finish and store the data. If you do not modify the code and value, please press **ESC** key to escape.

§ 5-2 Batching Modes

⇒ Batching Modes

1. Customer Programmed Control Mode: Normal Batching
2. Customer Programmed Control Mode: Loss-in-Weight Batching
3. Built-in Automatic Program Mode: Normal Batching
4. Built-in Automatic Program Mode: Loss-in-Weight Batching
5. 正 hold 功能

© 5-2-1 Customer Programmed Control Mode: Normal Batching (F101 =1)

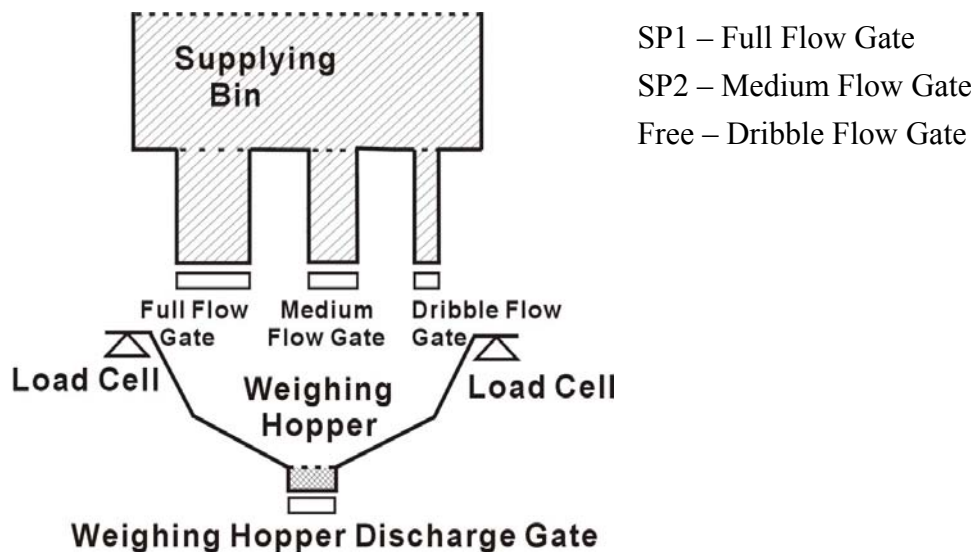

1. The weighing hopper is empty, the display shows “0”, and all gates are closed. If the display is not at ZERO, please input a **TARE** signal (Pin 24) to re-ZERO the display.
2. Open the Supply Bin’s: Full Flow Gate, Medium Flow Gate, and Dribble Flow Gate.
3. When the display reaches “**Final – SP1**”, the **SP1** output (Pin 12) signal will come **ON**. Close the Full Flow Gate by using the SP1 output ON signal.
4. When the display reaches “**Final – SP2**”, the **SP2** output (Pin 11) signal will come **ON**. Close the Medium Flow Gate by using the SP2 output ON signal.
5. When the display reaches “**Final – Free**”, the **Free** output (Pin 10) signal will come **ON**. Close the Dribble Flow Gate by using the Free Fall output ON signal.
6. After Free Fall has stopped, check if the HI and LO (Pin 9, Pin 8) signals are OFF. If both outputs are OFF, then the batch is completed correctly.
7. An Automatic Free Fall Compensation Command (Min. 200ms pulse to Pin 21) may be given at this time. If you change the Free Fall Set Points value either from the front panel or RS-232C, RS-422/485 – the learned Free Fall value will be cleared.
8. Use the Free (Pin 10) signal to delay a time period as the control signal is processing empty the weighing hopper.
9. When the GROSS weight is below the ZERO band, the ZERO band output will come **ON**–signifying the weighing hopper is empty. Close the weighing hopper discharge gate

by using the ZERO band (Pin 13) output ON signal.
 10. Now you are ready for your next batching event.

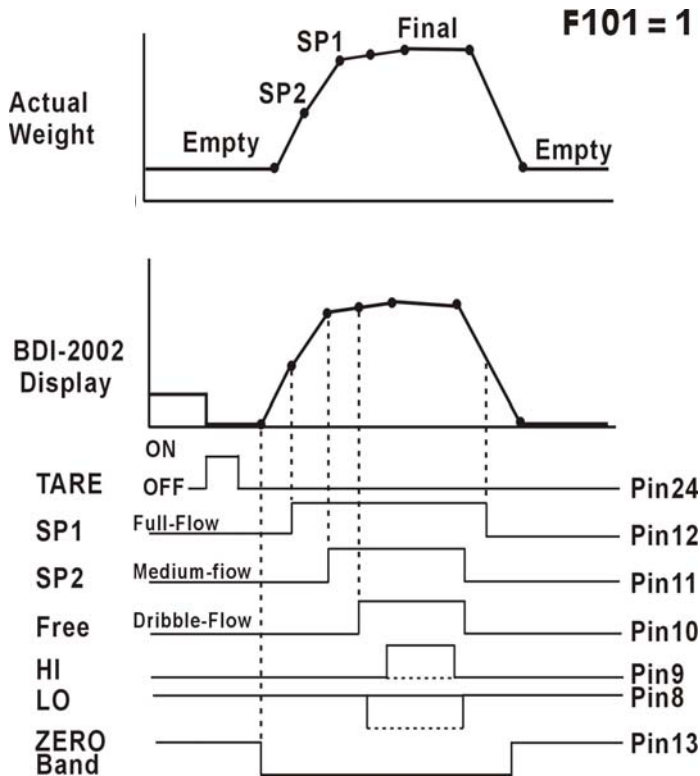

© 5-2-2 Customer Programmed
 Control Mode: Loss-in-Weight
 Batching (F101 =2)

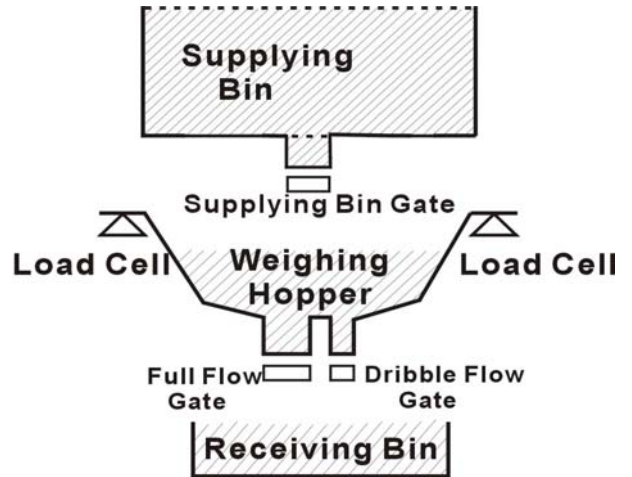

SP1 – Supplying Bin Gate
 SP2 – Full Flow Gate
 Free – Dribble Flow Gate

1. The weighing hopper is empty as the receiving bin. The display shows “0”, and all gates are closed.
2. Open the Supplying Bin Gate.
3. When the GROSS weight reaches “SP1”, the SP1 output (Pin 12) signal will come ON. Close the Supplying Bin Gate by using the SP1 output ON signal.
4. The displayed weight will exceed the SP1 value by the Free Fall value. This weight is not necessarily accurate, but accuracy is not needed at this moment since the purpose of this event is to fill up the weighing hopper. The SP1 value is always compared to GROSS weight.
5. Input a TARE signal (Pin 24) to ZERO the display.
6. Open the Full Flow Gate and the Dribble Flow Gate for Full Flow filling into the receiving bin.
7. When the display reaches “Final – SP2”, the SP2 output (Pin 11) signal will come ON. Close the Full Flow Gate by using the SP2 output ON signal.
8. When the display reaches “Final – Free”, the Free output (Pin 10) signal will come ON. Close the Dribble Flow Gate by using the Free output ON signal.
9. After Free Fall has stopped, check to see if the HI and LO (Pin 9, Pin 8) signals are

OFF. If both outputs are OFF then the batch is completed correctly.

10. An Automatic Free Fall Compensation Command (Min. 200ms pulse to Pin 21) may be given at this time.

11. If the GROSS weight of the weighing hopper is below the ZERO band (Pin 13), the ZERO band output will be ON. The ZERO band output will refill weighing hopper if needed.

12. Ready for next batching event.

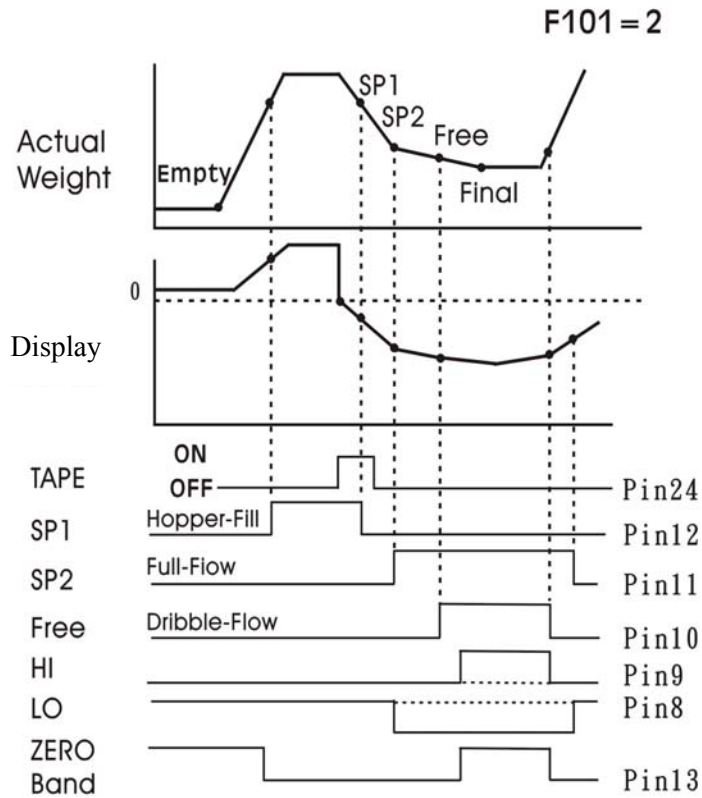

© 5-2-3 Automatic Program Mode: Normal Batching (F101 =3)

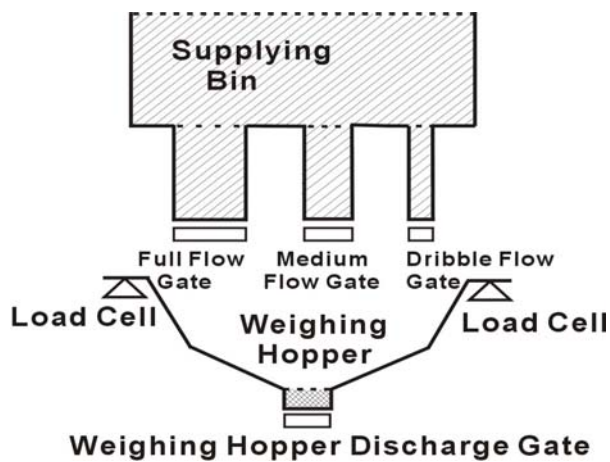

SP1 – Full Flow Gate
SP2 – Medium Flow Gate
Free – Dribble Flow Gate
Start signal – Pin 22

1. The weighing hopper is empty, the display shows “0”, and all gates are closed. If the display is not at ZERO, input a **TARE** signal (Pin 24) to re-ZERO the display.
2. Check if the weighing hopper is empty using the ZERO band output (Pin 13).
3. Input the start signal via the Control I/O Interface connector (Pin 22). When the start signal is received, then **SP1**, **SP2**, and Free output signals will come “ON”.

【Note: If the Final Weight is 0, the Pin 12,11, and 10 will be kept OFF.】

4. Open the Supply Bin’s: Full Flow Gate, Medium Flow Gate, and Dribble Flow Gate.
5. When the display reaches “**Final – SP1**”, the **SP1** output (Pin 12) signal will come **OFF**. Close the Full Flow Gate by using the **SP1** output OFF signal.
6. When the display reaches “**Final – SP2**”, the **SP2** output (Pin 11) signal will come **OFF**. Close the Medium Flow Gate by using the **SP2** output OFF signal.
7. When the display reaches “**Final – Free**”, the **Free** output (Pin 10) signal will come **OFF**. Close the Dribble Flow Gate by using the **Free** output OFF signal.
8. Batch finish signal is sent after the set time period (F103) or when the display is stable.
9. After Free Fall has stopped, check to see if the HI and LO (Pin 9, Pin 8) signals are OFF. If both outputs are OFF then the batch is completed correctly.
10. Automatic Free Fall is now recalculated for the next event.
11. The Weighing Hopper Discharge Gate will be opened using the Finish Output (Pin 7) ON signal.
12. Data Output is sent (Auto Print Mode: BCD, RS-232C, RS-422/485, Printer or Current Loop). The NET weight data will be accumulated.
13. Ready for the next batching event.
14. If an Abort signal is sent (Pin 21) anytime after the Start Signal is received, then
 - (1) SP1, SP2, and Free signals will go OFF, and Gates will be closed.
 - (2) Batch Finish and Data Output signals will be sent.
 - (3) NET weight data will be accumulated.

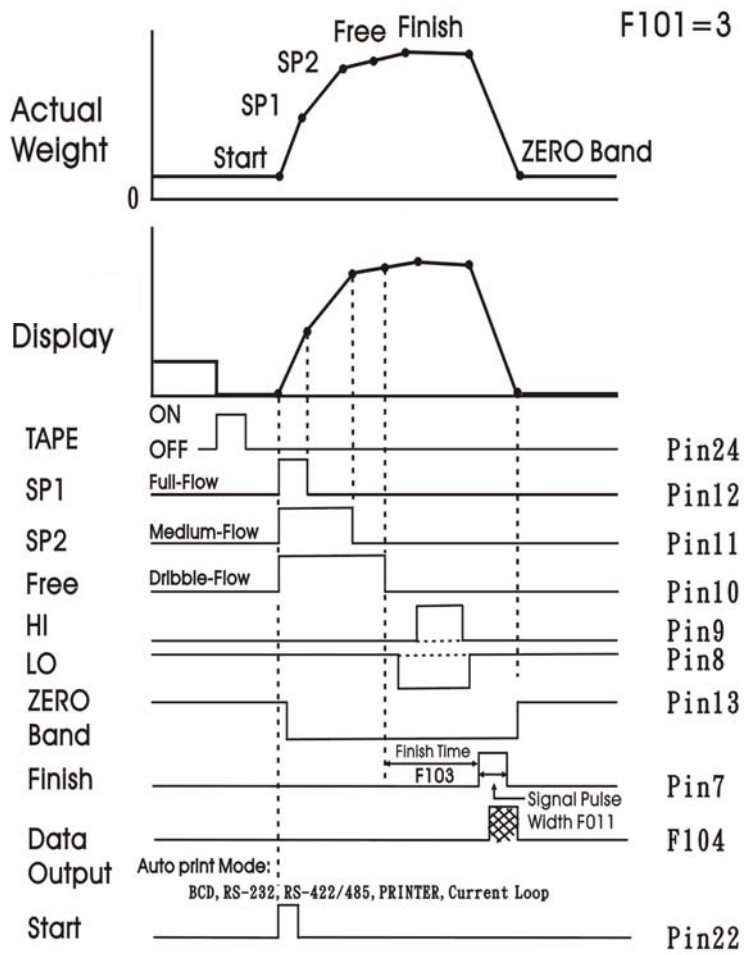

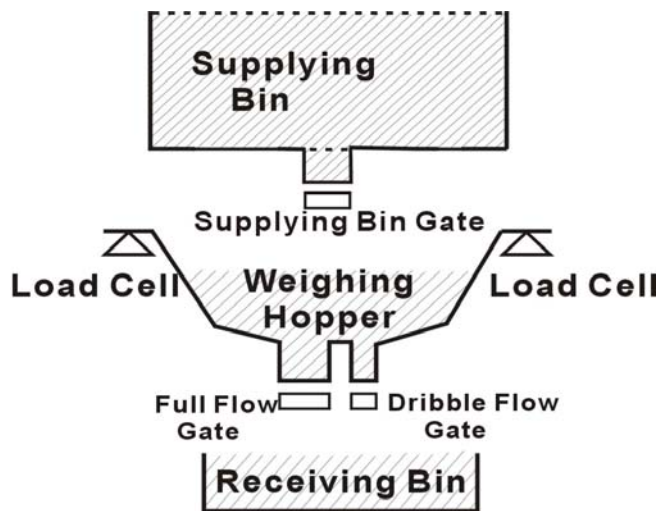

SP1 – Supplying Bin Gate

SP2 – Full Flow Gate

Free – Dribble Flow Gate

Start signal – Pin 22

1. The weighing hopper / supplying bin is empty. The display shows “0”, and all Gates are closed.
 2. Open the Supplying Bin Gate.
 3. When the GROSS weight reaches “SP1”, the SP1 output (Pin 12) signal will come ON. Close the supplying bin gate by using the SP1 output ON signal.
 4. The displayed weight will exceed the SP1 value by the Free Fall value. This weight is not necessarily accurate, but accuracy is not needed at this moment since the purpose of this event is to fill up the weighing hopper. The SP1 value is always compared to GROSS weight.
 5. Input a TARE signal (Pin 24) to ZERO display.
 6. Input the Start signal via the control I/O interface connector (Pin 22). When the start signal is received, the SP2 and Free outputs come “ON”.
- 【Note: If the Final Weight is 0, the Pin 11 and 10 will be kept OFF.】**
7. Open the Full Flow Gate and the Dribble Flow Gate for Full Flow filling into the receiving bin.
 8. When the display reaches “Final – SP2”, the SP2 output (Pin 11) signal will come OFF. Close the Full Flow Gate by using the SP2 output OFF signal.
 9. When the display reaches “Final – Free”, the Free output (Pin 10) signal will come OFF. Close the Dribble Flow Gate by using the Free output OFF signal.
 10. Batch Finish signal is sent after the set time period (F103) or when display is stable.
 11. After Free Fall has stopped, check if the HI and LO (Pin 9, Pin 8) signals are OFF. If both outputs are OFF then the batch is completed correctly.
 12. Automatic Free Fall is now recalculated for the next event.
 13. The Weighing Hopper Discharge Gate will be opened using the Finish Output (Pin 7) ON signal.
 14. Data Output is sent (Auto Print Mode: BCD, RS-232C, RS-422/485, Printer or Current Loop). The NET weight data will be accumulated.
 15. Signal (Pin 13) will refill using ZERO band output if needed.

16. Ready for the next batching event.

17. If an Abort signal is sent (Pin 21) anytime after the Start Signal is received, then

(1) SP1, SP2, and Free signals will go OFF, and Gates will be closed.

(2) Batch Finish and Data Output signals will be sent.

(3) NET weight data will be accumulated.

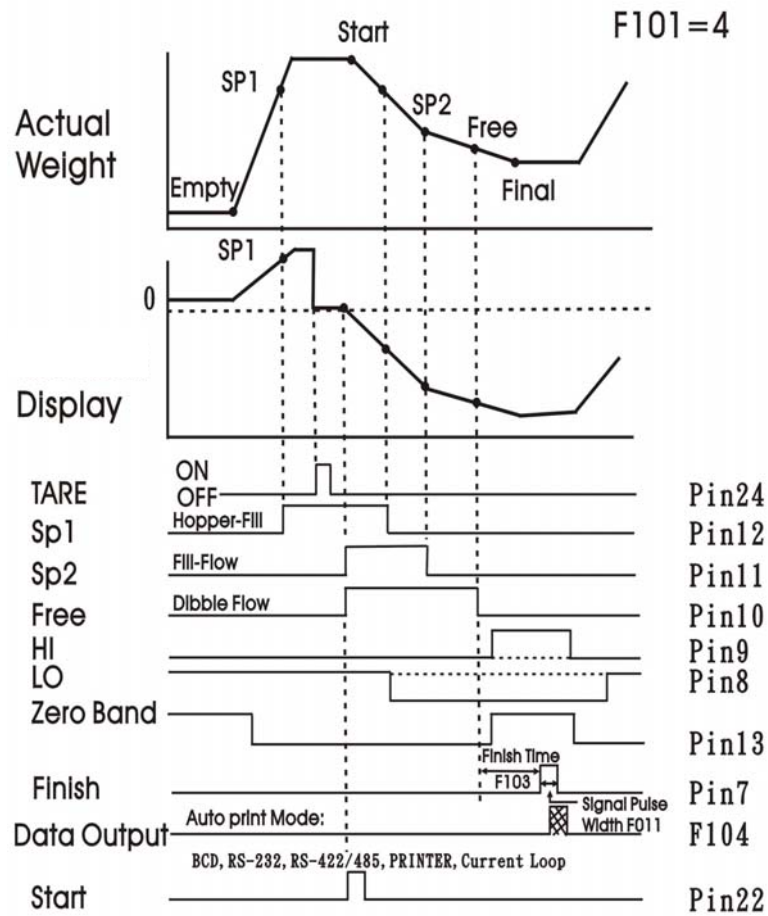

CHAPTER 6 OPTIONS

§ 6-1 I/O Interface

© Control I/O

Input:

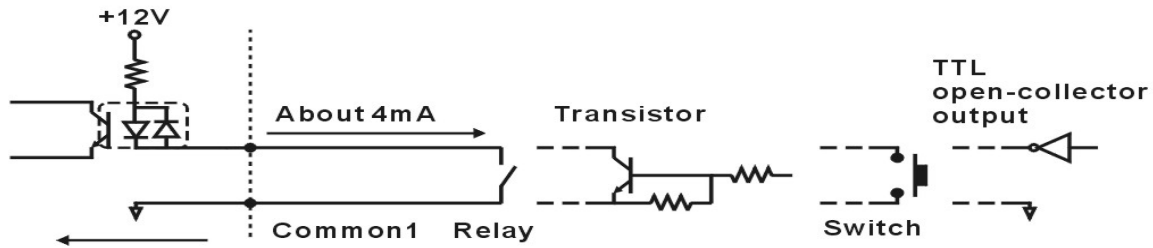

The width of these input pulses should at least 0.25 sec.

Output:

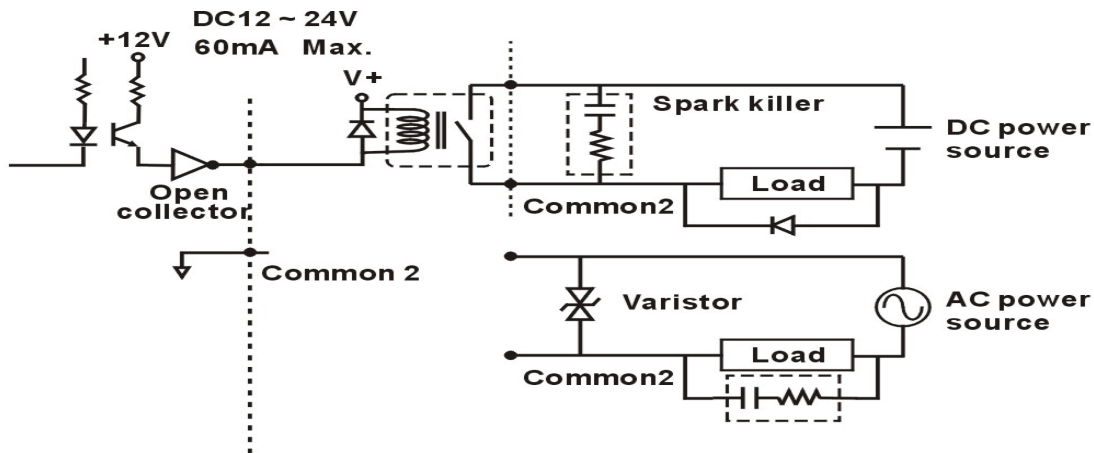

© INPUT Pins Description When F101=1,2.

Pin	Name	Signal	Description
Pin 25	ZERO Input	Pulse	BDE-2007-6KEY will ZERO according to F004.
Pin 24	TARE Input	Pulse	BDE-2007-6KEY will return to zero and store tared weight.
Pin 23	TARE Reset	Pulse	Clear tared weight.
Pin 21	Automatic free fall compensation when batching.	Pulse	When Pin 21 and COM1 get a short circuit, BDE-2007-6KEY will adjust compensation value for next batch and accumulate Net weight.
Pin 19	PRINT	Pulse	Send data (Please refer F202.)
Pin 18	Clear count and accumulation.	Pulse	Clear count and accumulation value.
Pin 17.16	Input Common (COM1)	Pulse	

© *INPUT Pins Description When F101=3,4.*

Pin	Name	Signal	Description
Pin 25	ZERO Input	Pulse	BDE-2007-6KEY will ZERO according to F004.
Pin 24	TARE Input	Pulse	BDE-2007-6KEY will return to zero and store tared weight.
Pin 23	TARE Reset	Pulse	Clear tared weight.
Pin 22	Batch/Loss-in- weight Start Batch (Pulse Input)	Pulse	Start batch.
Pin 21	Batch/Loss-in-weight Stop Batch (Pulse Input)	Pulse	Stop batch, send finish signal, and accumulate net weight.
Pin 19	PRINT	Pulse	Send data (Please refer F202.)
Pin 18	Clear count and accumulation.	Pulse	Clear count and accumulation value.
Pin 17.16	Input Common (COM1)	Pulse	

© *OUTPUT Pins Description When F101=1,2,3,4.*

Pin	Name	F101	Description
Pin 13	ZERO Band	1,2,3,4	Gross Weight \leq ZERO Band
Pin 12	SP1	1,3	Batch: Net Weight \geq Final Weight – SP1
		2,4	Loss-in-Weight: Gross Weight $>$ SP1
Pin 11	SP2	1,2,3,4	Net Weight \geq Final Weight – SP2
Pin 10	FF	1,2,3,4	Net Weight \geq Final Weight – FF
Pin 9	HI	1,2,3,4	Net Weight $>$ Final Weight + Hi value
Pin 8	LO	1,2,3,4	Net Weight $<$ Final Weight + Lo value
Pin 7	FINISH	3,4	Batch/Loss-in-weight: Final Output – Finish Signal
Pin 6	Unstable / Error	1,2,3,4	F105 = 0 : Stable : Open, Unstable : Short F105 = 1 : Error output, ZERO exceeds valid range, Overload, or Printer error.
Pin 1.2	Output Common (COM2)	1,2,3,4	

§ 6-2 Serial Interface (OP-02)

There are two kinds of OP-02:

- (1) High speed two way (Rx/D, Tx/D)
- (2) Low speed one way (Tx/D2)

© 6-2-1 OP-02A (RS-232)

◆ Specifications	
Type	EIA-RS-232C
Transmission	Half Duplex, Asynchronous Transmission
Baud Rate	2400 、 4800 、 9600BPS
Bit	8 bit 7 bit
Parity	Non- parity Odd / even parity
Stop bit	1 bit
Output Code	ASCII

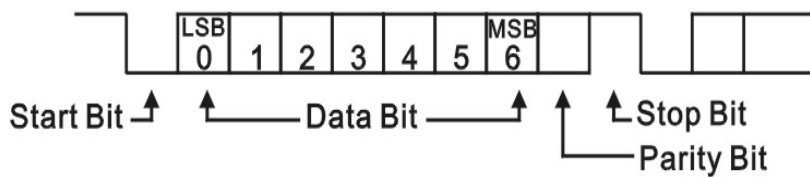

25 Pin assignments:

Serial	Pin	Assignment
	Pin 1	TxD2 (Transmit Data)
	Pin 2	SG (Signal Ground)
	Pin 3	RxD (Receive Data)
	Pin 4	TxD (Transmit Data)

© 6-2-2 OP-02B (RS-485)

◆ RS-485 Specifications :	
Type	EIA-RS-485
Transmission	Half Duplex, Asynchronous Transmission
Baud Rate	2400BPS 、 4800BPS 、 9600BP
Bit	8 bit
Parity	Non- parity Odd / even parity
Stop bit	1 bit 、 2 bit
Output Code	ASCII

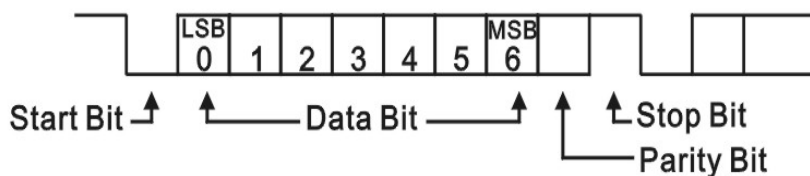

◆ Pins when connect PC :

DC Serial Load Cell

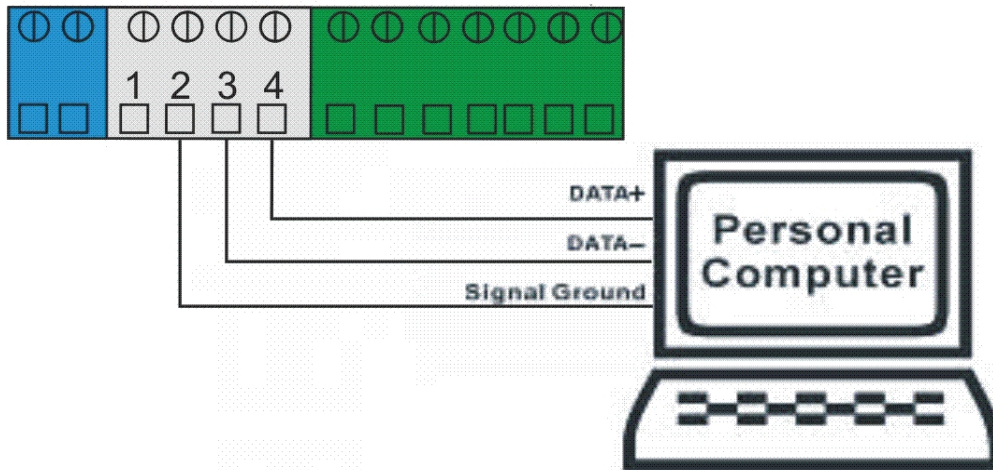

◎ 6-2-3 Data Format for Serial Output Interface (OP-02)

※ F205=0 (Standard) :

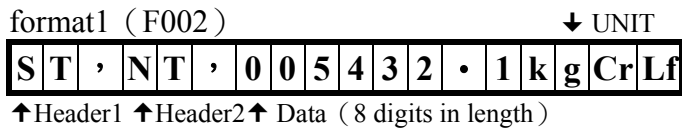

※ HEADER 1	
O L	→ Over Max. Capacity or under Min. Capacity
S T	→ STABLE
U S	→ UNSTABLE

※ HEADER 2	
N	→ NET
G	→ GROSS
T	→ TARE

※ UNIT		
k	g	→ Kilogram
l	b	→ Pound
t	t	→ Ton

ASCII data characters:

- “ 0 ” ~ “ 9 ” (30H ~ 39H)
- “ ” Space (20H)
- “ . ” Decimal Point (2EH)
- “ - ” Minus (2DH)
- “ + ” Plus (2BH)

※ F205=1 (BDI-9301) :

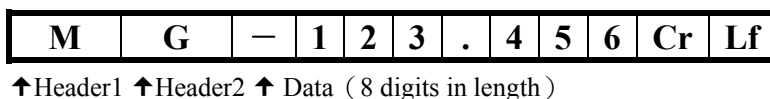

※ HEADER 1	
M	→ UNSTABLE
S	→ STABLE
O	→ OVERWEIGHT

※ HEADER 2	
G	→ GROSS
N	→ NET

※ Positive or Negative	
Space	→ Positive Value
—	→ Negative Value

※ F205=2 (IQ-350) :

STX	—	1	2	3	.	4	5	6	K	G	M	Cr	Lf
-----	---	---	---	---	---	---	---	---	---	---	---	----	----

↑ Data (8 digits in length) ↑Unit ↑Status 1 ↑Status 2

STX=02H

※ STATUS 1	
G	→ GROSS
N	→ NET

※ STATUS 2	
M	→ UNSTABLE
O	→ OVERWEIGHT
S	→ STABLE

※ UNIT	
L	→ Pound
K	→ Kilogram
T	→ Ton
SPACE	→ Gram
O	→ Ounce

※ Positive or Negative	
Space	→ Positive Value
—	→ Negative Value

※ F205=3 (HB-8210) :

STX	—	1	2	3	.	4	5	6		K	g		G	R	M	Cr	Lf
-----	---	---	---	---	---	---	---	---	--	---	---	--	---	---	---	----	----

↑ Data (8 digits in length) ↑Space ↑Unit ↑Space ↑Status 1 ↑Status 2

STX=02H, Space=20H

※ STATUS 1	
GR	→ GROSS
NT	→ NET

※ STATUS 2	
M	→ UNSTABLE
O	→ OVERWEIGHT
S	→ STABLE

※ UNIT	
Kg	→ Kilogram
t	→ Ton
g	→ Gram
Lb	→ Pound
Oz	→ Ounce

© 6-2-4 Command List Table

Sending Command to BDE-2007-6KEY	BDE-2007-6KEY Response
R01 Cr Lf < READ >	Sending latest data once (Data format depends on F202)
K01 Cr Lf < ZERO >	BDE-2007-6KEY display will ZERO. K01 Cr Lf will be sent by BDE-2007-6KEY.
K02 Cr Lf < TARE >	BDE-2007-6KEY will go to NET Mode and display will TARE. K02 Cr Lf will be sent by BDE-2007-6KEY.
K03 Cr Lf < GROSS >	BDE-2007-6KEY will go to GROSS Mode. K03 Cr Lf will be sent by BDE-2007-6KEY.
K04 Cr Lf < NET >	BDE-2007-6KEY will go to NET Mode. K04 Cr Lf will be sent by BDE-2007-6KEY.

Sending Command to BDE-2007-6KEY	BDE-2007-6KEY Response
C01 Cr Lf 〈 BEGIN BATCHING 〉	Send back signal “BB”. “BB” can only be received in the Built in Automatic Program Control Mode. (Only F101=3,4)
C02 Cr Lf 〈 HALT BATCHING 〉	Send back signal “HB”. “HB” an only be received in the Built in Automatic Program Control Mode (Only F101=3,4)
R04 Cr Lf 〈 READS FINAL NET 〉	Sending Final NET weight. If B Cr Lf is send by BDE-2007-6KEY, that means batching is still in process. (Only F101=3,4)
W02: Data Cr Lf 〈 SETPOINT 〉	Signal “S Cr Lf” will send back by BDE-2007-6KEY. BDE-2007-6KEY will send back SET POINT CODE until totally receive SET POINT CODE data.
R03 Cr Lf 〈 READ SETPOINT 〉	SS XX Cr Lf will send back by BDE-2007-6KEY. BDE-2007-6KEY will send back SET POINT values until totally receive SET POINT values.
W01: Data Cr Lf 〈 SET ACCESSORIES 〉	BDE-2007-6KEY will send back signal “SA Cr Lf”. BDE-2007-6KEY will send back ZERO band data until totally receive Zero Band Value.
R02 Cr Lf 〈 READ ACCESSORIES 〉	BDE-2007-6KEY receives signal “RS Cr Lf”.

※ If the commands are not accepted for any reason: **I Cr Lf** will be sent by BDE-2007-6KEY.

※ **Error message**

BDE-2007-6KEY Error number	BDE-2007-6KEY Error message
E01	The format of command is not correct.
E02	The data of command is not correct.
E03	Data cannot be accepted.
E04	Can not execute.
E05	Indicator is busy.

◎ **6-2-5 W02 Command Format**

Tx:

W	0	2	:
---	---	---	---

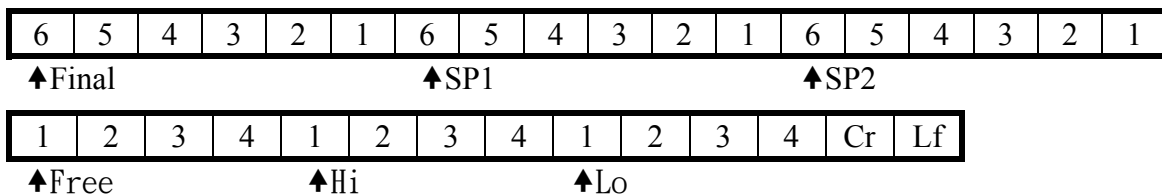

◎ 6-2-6 W01 Command Format

Tx:

W	0	1	:
---	---	---	---

0	0	2	0	0	0	Cr	Lf
---	---	---	---	---	---	----	----

↑Zero Range

※Please setup F204 first and give command @XX (XX=F204)
 Ex: @XX R01 Cr Lf @XX K01 Cr Lf

§ 6-3 Analog Output (OP-05)

☒ Please refer to ◎ 4-2-4 F500 ~ F504

◎ 6-3-1 OP-05 Analog Output 4~20mA

* OP-05 Set at Analog 4 ~ 20mA

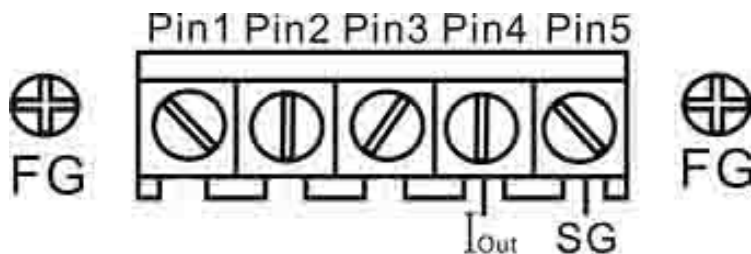

Range	4 ~ 20mA (Possible: 0 ~ 24mA)
Resolution	1 / 4000
Temp. coefficient	± (0.015% / °C of rdg + 0.01mA) / °C
Max. resistance load	Max.250Ω

● If you add a 250Ω resistor, the output will be 1V to 5V (4~20mA)

① This resistor must be large enough for proper power consumption.

Use the following formula: $W = I^2 \times R$

where

W: Power I: Output Current

R: Resistor

If a 500Ω resistor is used, power consumption will be :

$W = (0.02)^2 \times 500 = 0.2$ when the Output Current is set to 0.2mA

The resistor should have a power greater than "0.5" (w = 0.5) and have a very low temperature coefficient. In this example power consumption is "0.2" and thus, the 500Ω resistor is adequate.

● Setting Output Current

$I_{OUT} = I_Z + (\text{weight} / \text{capacity}) * (I_M - I_Z)$ (if $2 \leq I_{OUT} \leq 22 \text{ mA}$)

I_{OUT} : Output Current I_Z : Output at ZERO (F501) I_M : Output at Maximum Capacity (F502)

Example: A weighing system has a Maximum Capacity of 10,000kg.

If you need the Output current to be 4mA at ZERO display, and 20mA at 1/2

Maximum Capacity then:

$I_M = \text{capacity} / \text{simulated}) \times (I_{OUT} - I_Z) + I_Z$

$I_M = 10000 / 5000 \times (20 \text{ mA} - 4 \text{ mA}) + 4 \text{ mA} = 36 \text{ mA}$

When Output at Full Scale is set at 36mA, and Output Current at Display ZERO is set at 4mA, then at 1/2 Capacity (5000kg) the Output Current will be 20mA.

※ NOTE: The Maximum Output will be saturated at 24mA.

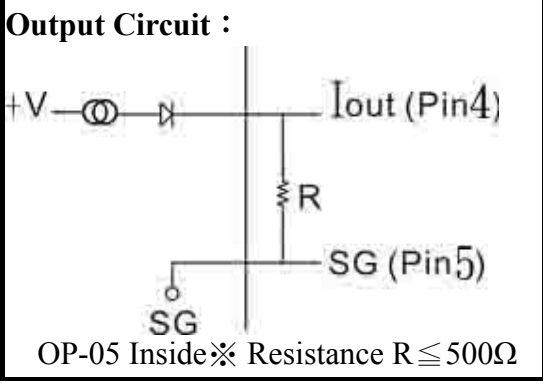

* OP-05 Set at Analog 0 ~ 10V

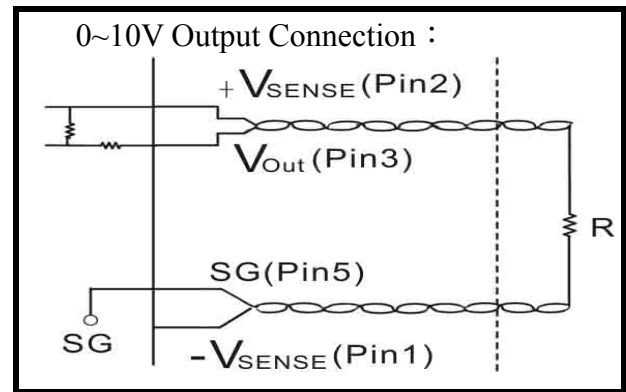
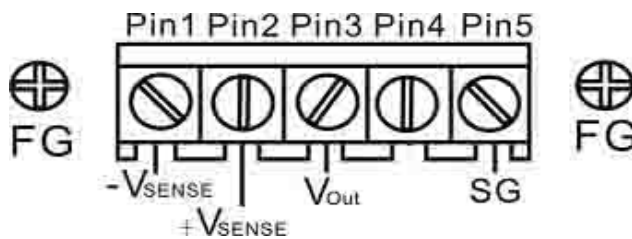

If you set at 0-10V, please also connect V_+ V. as follows. °

• If you add a 10KΩ resistor, the output will be 0mA to 1mA (0~10 V)

① This resistor must be large enough for proper power consumption.

Use the following formula: $W = V^2 / R$

where

W: Power V: Output Voltage R: Resistor

• **Setting Output Voltage**

$$V_{OUT} = V_Z + (\text{weight} / \text{capacity}) * (V_M - V_Z) \quad (\text{if } 0 \leq V_{OUT} \leq 10 \text{ V})$$

V_{OUT} : Output Voltage

V_Z : Output at ZERO (F503)

V_M : Output at Maximum Capacity (F504)

NOTE: The Maximum Output will be saturated at 10 (V).

Range	0 ~ +10V , (Possible: 0 ~ 10V)
Resolution	1 / 4000
Temp. coefficient	$\pm (0.015\% / ^\circ\text{C} \text{ of rdg} + 0.01\text{mA}) / ^\circ\text{C}$
Max. resistance load	Min. 10KΩ

§ 6-4 Relay Control Interface (OP-08)

This option is to connecting BDE-2007-6KEY OP-01 Control I/O, which enable OP-01 to RELAY OUTPUT.

Specifications:

Power : Standard : DC 24V from Outside.

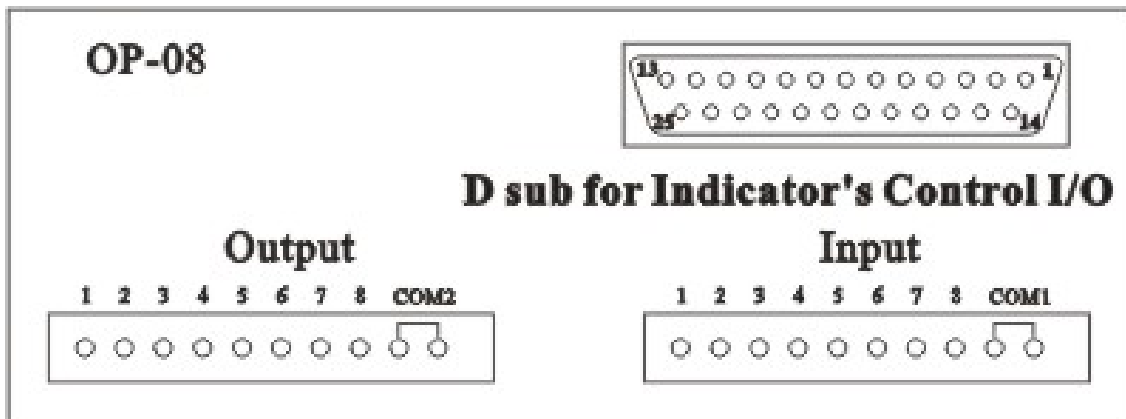

Accessory :

(1) 5 PIN Male to Female Wire 1.8 Meter.

(A) RELAY TYPE

Input (IN):

Number of Pins: 8.

Input Common Pin: COM1

Output (OUT):

Number of Pins : 8.

Type : for RELAY.

Max. Load : 250VAC, 30VDC, 3A

Output Common Pin : COM2

RELAY durance : About 100,000 times.

LED light will ON when work.

CONTROL I/O Pins		
	OP-08 I/O	BDE-2007-6KEY Control I/O
Input	1	PIN 25
	2	PIN 24
	3	PIN 23
	4	PIN 22
	5	PIN 21
	6	PIN 20
	7	PIN 19
	8	PIN 18
Output	1	PIN 13
	2	PIN 12
	3	PIN 11
	4	PIN 10
	5	PIN 9
	6	PIN 8
	7	PIN 7
	8	PIN 6

(B) SSR TYPE

Input (IN)

Number of Pins : 8.

Input Common Pin : COM1

Output (OUT):

Number of Pins : 8.

Type : for RELAY.

Max. Load : 24~280VAC, 3A (Only for AC)

Output Common Pin : COM2

LED light will ON when work.

§ 6-5 Modbus

☒ Please refer to ☉ 4-2-3 F200 ~ F204

◆ Modbus:	
Address	1~99
Baud Rate	2400BPS、4800BPS、9600BP
Bit	8 bit
Parity	Non-parity、Odd parity、Even parity
Stop bit	1 bit、2 bit
Output Code	Modbus RTU

☉ 6-5-1 Modbus Data Address Table

Data Register					
R/W	Type	Function	Address	Modbus Address	Description
R	Word	R:04	0000 ~ 0001	30001 ~ 30002	Same as display
R	Word	R:04	0002 ~ 0003	30003 ~ 30004	G.W.
R	Word	R:04	0004 ~ 0005	30005 ~ 30006	N.W.
R	Word	R:04	0006 ~ 0007	30007 ~ 30008	Tare Value
R	Word	R:04	0008 ~ 0009	30009 ~ 30010	Accumulation
R	Word	R:04	0010 ~ 0011	30011 ~ 30012	Total Count
R	Word	R:04	0012 ~ 0013	30013 ~ 30014	Actual Final
R/W	Word	R:03,W:06	0000 ~ 0001	40001 ~ 40002	Final
R/W	Word	R:03,W:06	0002 ~ 0003	40003 ~ 40004	SP1
R/W	Word	R:03,W:06	0004 ~ 0005	40005 ~ 40006	SP2
R/W	Word	R:03,W:06	0006 ~ 0007	40007 ~ 40008	FF
R/W	Word	R:03,W:06	0008 ~ 0009	40009 ~ 40010	HI
R/W	Word	R:03,W:06	0010 ~ 0011	40011 ~ 40012	LO

Bit I/O					
R/W	Type	Function	Address	Modbus Address	SCALE Input
R/W	Bit	R:01,W:05	0	00001	ZERO
R/W	Bit	R:01,W:05	1	00002	TARE
R/W	Bit	R:01,W:05	2	00003	TARE Cleared
R/W	Bit	R:01,W:05	3	00004	Display G.W.
R/W	Bit	R:01,W:05	4	00005	Display N.W.
R/W	Bit	R:01,W:05	30	00049	Add 1
R/W	Bit	R:01,W:05	31	00050	Clear ACC and Count
R/W	Bit	R:01,W:05	32	00051	Start Batch
R/W	Bit	R:01,W:05	33	00052	Stop Batch

Bit I/O					
R/W	Type	Function	Address	Modbus Address	SCALE Output
R	Bit	R:02	0	10001	ZERO
R	Bit	R:02	1	10002	M.D.
R	Bit	R:02	2	10003	G.W.
R	Bit	R:02	3	10004	N.W.
R	Bit	R:02	4	10005	Tared
R	Bit	R:02	5	10006	OVER
R	Bit	R:02	30	10049	Zero Range
R	Bit	R:02	31	10050	SP1
R	Bit	R:02	32	10051	SP2
R	Bit	R:02	33	10052	FF
R	Bit	R:02	34	10053	HI
R	Bit	R:02	35	10054	LO
R	Bit	R:02	36	10055	Finish
R	Bit	R:02	37	10056	Unstable / Error

6-5-2 Function codes descriptions

01(0x01) Read Coils

Request:

Field Name		(Hex)
Address	1 Bytes	0 to 99(0x63)
Function code	1 Bytes	0x01
Starting Address	2 Bytes	0x0000 to 0x00FF
Quantity of coils	2 Bytes	1 to 53(0x35)
CRC Check	2 Bytes	

Response:

Field Name		(Hex)
Address	1 Bytes	0 to 99(0x63)
Function code	1 Bytes	0x01
Byte count	1 Bytes	N
Coil Status	n Bytes	n=N or N+1
CRC Check	2 Bytes	

$N = \text{Quantity of Outputs} / 8$, if the remainder is different of 0 $\Rightarrow N = N+1$

Example:

Read from zero to net (0-4).

Request		Response	
Field Name	(Hex)	Field Name	(Hex)
Address	01	Address	01
Function code	01	Function code	01
Starting Address Hi	00	Byte Count	01
Starting Address Lo	00	Outputs status 4-0	00
Quantity of Outputs Hi	00	CRC Check Hi	51
Quantity of Outputs Lo	05	CRC Check Lo	88
CRC Check Hi	FC		
CRC Check Lo	09		

Output 4-0 according to 2 step 00000000(B) , Output 0 /Bit0
output4 /Bit4

02(0x02) Read Discrete inputs

Request:

Field Name		(Hex)
Address	1 Bytes	0 to 99(0x63)
Function code	1 Bytes	0x02
Starting Address	2 Bytes	0x0000 to 0x00FF
Quantity of Inputs	2 Bytes	1 to 57(0x39)
CRC Check	2 Bytes	

Response:

Field Name		(Hex)
Address	1 Bytes	0 to 99(0x63)
Function code	1 Bytes	0x02
Byte count	1 Bytes	N
Inputs Status	n Bytes	n=N or N+1
CRC Check	2 Bytes	

N = Quantity of Outputs / 8 , if the remainder is different of 0 ⇒ N = N+1

Example:

Read zero to OVER (0-5)

Request		Response	
Field Name	(Hex)	Field Name	(Hex)
Address	01	Address	01
Function code	02	Function code	02
Starting Address Hi	00	Byte Count	01
Starting Address Lo	00	Inputs status 5 to 0	26
Quantity of Inputs Hi	00	CRC Check Hi	20
Quantity of Inputs Lo	06	CRC Check Lo	52
CRC Check Hi	F8		
CRC Check Lo	08		

Output 5-0 according to 2 step 00100110(B) , Output 0/Bit0, output 5/Bit5

03(0x03) Read Holding Registers

Request:

Field Name		(Hex)
Address	1 Bytes	0 to 99(0x63)
Function code	1 Bytes	0x03
Starting Address	2 Bytes	0x0000 to 0x00FF
Quantity of Registers	2 Bytes	1 to 12(0x0C)
CRC Check	2 Bytes	

Response:

Field Name		(Hex)
Address	1 Bytes	0 to 99(0x63)
Function code	1 Bytes	0x03
Byte count	1 Bytes	2*N
Register value	N*2 Bytes	
CRC Check	2 Bytes	

N = Quantity of Registers

Example:

Read Final to Sp1 (0-3)

Request		Response	
Field Name	(Hex)	Field Name	(Hex)
Address	01	Address	01
Function code	03	Function code	03
Starting Address Hi	00	Byte Count	08
Starting Address Lo	00	Register value Hi (0)	13
No. of Registers Hi	00	Register value Lo (0)	88
No. of Registers Lo	04	Register value Hi (1)	00
CRC Check Hi	44	Register value Lo (1)	00
CRC Check Lo	09	Register value Hi (2)	0B
		Register value Lo (2)	B8
		Register value Hi (3)	00
		Register value Lo (3)	00
		CRC Check Hi	5E
		CRC Check Lo	C7

04(0x04) Read Input Registers

Request:

Field Name		(Hex)
Address	1 Bytes	0 to 99(0x63)
Function code	1 Bytes	0x04
Starting Address	2 Bytes	0x0000 to 0x00FF
Quantity of Input Registers	2 Bytes	1 to 14(0x0E)
CRC Check	2 Bytes	

Response:

Field Name		(Hex)
Address	1 Bytes	0 to 99(0x63)
Function code	1 Bytes	0x04
Byte count	1 Bytes	2*N
Input Registers	N*2 Bytes	
CRC Check	2 Bytes	

N = Quantity of Input Registers

Example:

Read Gross weight from display (0-3)

Request		Response	
Field Name	(Hex)	Field Name	(Hex)
Address	01	Address	01
Function code	04	Function code	04
Starting Address Hi	00	Byte Count	08
Starting Address Lo	00	Input Register value Hi (0)	0B
Quantity of Input Registers Hi	00	Input Register value Lo (0)	7A
Quantity of Input Registers Lo	04	Input Register value Hi (1)	00
CRC Check Hi	F1	Input Register value Lo (1)	00
CRC Check Lo	C9	Input Register value Hi (2)	0B
		Input Register value Lo (2)	7A
		Input Register value Hi (3)	00
		Input Register value Lo (3)	00
		CRC Check Hi	9D
		CRC Check Lo	84

05(0x05) Write Single Coil

Request:

Field Name		(Hex)
Address	1 Bytes	0 to 99(0x63)
Function code	1 Bytes	0x05
Output Address	2 Bytes	0x0000 to 0x00FF
Output Value	2 Bytes	1 to 53(0x35)
CRC Check	2 Bytes	

Response:

Field Name		(Hex)
Address	1 Bytes	0 to 99(0x63)
Function code	1 Bytes	0x05
Output Address	2 Bytes	0x0000 to 0x00FF
Output Value	2 Bytes	1 to 53(0x35)
CRC Check	2 Bytes	

N = Quantity of Input Registers

Example:

Write in TARE.

Request		Response	
Field Name	(Hex)	Field Name	(Hex)
Address	01	Address	01
Function code	05	Function code	05
Output Address Hi	00	Output Address Hi	00
Output Address Lo	01	Output Address Lo	01
Output value Hi	FF	Output value Hi	FF
Output value Lo	00	Output value Lo	00
CRC Check Hi	DD	CRC Check Hi	DD
CRC Check Li	FA	CRC Check Li	FA

06(0x06) Write Single Register

Request:

Field Name		(Hex)
Address	1 Bytes	0 to 99(0x63)
Function code	1 Bytes	0x03
Register Address	2 Bytes	0x0000 to 0x00FF
Register value	2 Bytes	1 to 12(0x0C)
CRC Check	2 Bytes	

Response:

Field Name		(Hex)
Address	1 Bytes	0 to 99(0x63)
Function code	1 Bytes	0x03
Register Address	2 Bytes	0x0000 to 0x00FF
Register value	2 Bytes	1 to 12(0x0C)
CRC Check	2 Bytes	

Example:

Write in 5000 to Final

Request		Response	
Field Name	(Hex)	Field Name	(Hex)
Address	01	Address	01
Function code	06	Function code	06
Registers Address Hi	00	Registers Address Hi	00
Registers Address Lo	00	Registers Address Lo	00
Registers value Hi	13	Registers value Hi	13
Registers value Lo	88	Registers value Lo	88
CRC Check Hi	84	CRC Check Hi	84
CRC Check Lo	9C	CRC Check Lo	9C

16(0x10) Write Multiple Register

Request:

Field Name		(Hex)
Address	1 Bytes	0 to 99(0x63)
Function code	1 Bytes	0x10
Starting Address	2 Bytes	0x0000 to 0x00FF
Quantity of Registers	2 Bytes	1 to 12(0x0C)
Byte Count	1 Bytes	2*N
CRC Check	2 Bytes	

Response:

Field Name		(Hex)
Address	1 Bytes	0 to 99(0x63)
Function code	1 Bytes	0x10
Starting Address	2 Bytes	0x0000 to 0x00FF
Quantity of Registers	2 Bytes	1 to 12(0x0C)
CRC Check	2 Bytes	

Example: Write 5000 to Final , 3000 to SP1

Request		Response	
Field Name	(Hex)	Field Name	(Hex)
Address	01	Address	01
Function code	10	Function code	10
Starting Address Hi	00	Starting Address Hi	00
Starting Address Lo	0	Starting Address Lo	00
Quantity of Registers Hi	00	Quantity of Registers Hi	00
Quantity of Registers Lo	0C	Quantity of Registers Lo	0C
Byte Count	18	CRC Check Hi	C0
Register value Hi	13	CRC Check Lo	0C
Register value Lo	88		
Register value Hi	00		
Register value Lo	00		
Register value Hi	0B		
Register value Lo	B8		
Register value Hi	00		

Register value Lo	00		
Register value Hi	03		
Register value Lo	E8		
Register value Hi	00		
Register value Lo	00		
Register value Hi	0		
Register value Lo	64		
Register value Hi	00		
Register value Lo	00		
Register value Hi	00		
Register value Lo	0A		
Register value Hi	00		
Register value Lo	00		
Register value Hi	00		
Register value Lo	0A		
Register value Hi	00		
Register value Lo	00		
CRC Check Hi	5C		
CRC Check Lo	38		

Error

Field Name		(Hex)
Address	1 Bytes	0 to 99(0x63)
Function code	1 Bytes	Function code + 0x80
Exception code	1 Bytes	01 or 02 or 03 or 04
CRC Check	2 Bytes	

- 01 Function Code Error.
- 02 Address Error.
- 03 Not acceptable ($0x0000 \leq \text{Register Value} \Rightarrow 0xFFFF$).
- 04 Can not execute.

【CHARACTERS】

0 1 2 3 4 5 6 7 8 9

0 1 2 3 4 5 6 7 8 9

A B C D E F G H I J K L M

A b C d E F G H i j k l ñ

N O P Q R S T U V W X Y Z

n o P q r s t U u v y y z
